



36V 50AH BLUETOOTH

Lithium Iron
Phosphate
Battery
(LiFePO₄)

Item# 3650-BT

USER MANUAL

Thank You!

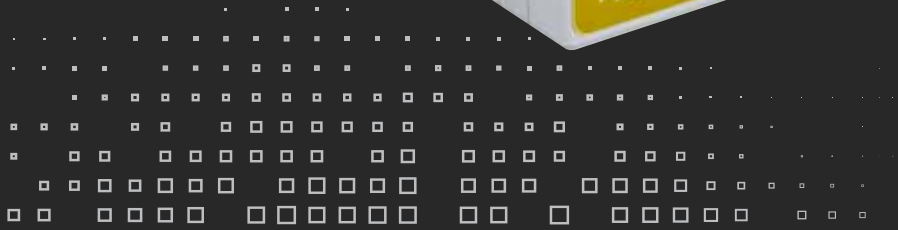

FOR YOUR BUSINESS, YOUR TRUST,
AND CONFIDENCE
IN MILLERTECH®.

*IT IS OUR
PLEASURE
TO SERVE
YOU!*



MillerTech

PRODUCT OVERVIEW

Positive Terminal

Negative Terminal



- 1 — 36V 50AH LiFePO₄ Millertech® Battery
- 1 — Nylon Strap Handle
- 2 — 8MM Stainless Terminal Bolts
- 1 — Red Terminal Cover
- 1 — Black Terminal Cover

Millertech[®]



BATTERY PARAMETERS

Specifications

CAPACITY	50AH
ENERGY STORAGE	1.92KWH
NOMINAL VOLTAGE	38.4V
FLOAT VOLTAGE	40.2V
SELF DISCHARGE RATE	< 4% / MONTH
TORQUE SETTING	10 FT-LBS.
COLD CRANKING AMPS (CCA)	1200

Charging

MAX CHARGE VOLTAGE	43.5V
MAX CHARGE CURRENT	50A
RECOMMENDED CURRENT	10A
CHARGE TEMPERATURE RANGE	25-131°F
RECOMMENDED CV	15 MIN

Discharging

MAX CONTINUOUS DISCHARGE CURRENT	50A
DISCHARGE CURRENT 5S	100A
DISCHARGE TEMP. RANGE	-4-140°F
DISCHARGE CUT OFF VOLTAGE	30V (ANY CELL 2.5)
RECOMMENDED LOW VOLTAGE DISCONNECT	36V

CHARGING PARAMETERS

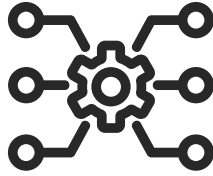

I BULK/ABSORPTION

For your Bulk/Absorption stage, the ideal voltage is between 43.2V-43.8V. For charge and balance, the absorption mode should be set to last for at least 20 minutes per battery (for multiple batteries in parallel).

I FLOAT

LiFePO₄ Batteries do not need a float stage for charging, but a float voltage between 40.5V and 41.4V can be used when connected to shore power.

I EQUALIZATION

Equalization is not recommended for our batteries. Most chargers will allow you to shut this feature off or use a setting that does not use equalization. If you cannot turn off this mode, then you will need to adjust the equalization voltage to below 43.8V and 0 hrs.

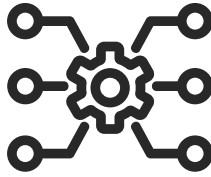

I TEMPERATURE COMPENSATION

Temperature compensation is not needed with our batteries and in some cases, may trigger the built-in BMS to go into protect mode. For this reason we recommend that temperature compensation be shut off or set to 0.

I LOW BATTERY DISCONNECT/SHUT DOWN

If an individual cell falls below 2.5V/30V during discharge, the battery will shut off the output current. At this time there will be only 1 or 2V present at the terminals. When this happens a standard lead acid battery charger will not be able to recognize the battery and will not start the charging process. For this reason we highly recommend using an approved LiFePO4 lithium battery charger.

BMS BASIC FEATURES

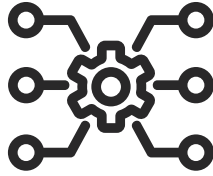

All Millertech® Batteries come with a built-in battery management system (BMS) that protects the cells for long-term cycling. The BMS protects against the following conditions.

I HIGH VOLTAGE: >44.4V or 3.75V per cell

If an individual cell voltage exceeds 3.75V during charging, the BMS will prevent a charge current from continuing. Discharge is always allowed under this condition.

I LOW VOLTAGE: <30V

If an individual cell falls below 2.5V during discharge, the BMS will prevent further discharge. Although the battery is in “low-voltage disconnect” mode, it will still allow a charging current.

BMS BASIC FEATURES

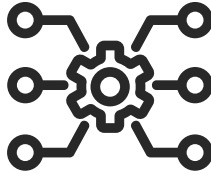

I HIGH TEMPERATURE: >150°F

The BMS will not allow a charging current or discharging current.

I LOW TEMPERATURE: <24°F

The BMS will not allow a charging current.

I HIGH CURRENT

The BMS allows constant current 50A ($\pm 5\%$) amps, 100A ($\pm 10\%$) amps for 3 seconds.

A passive balancing process is activated by the BMS at the top of each charge cycle, when the battery voltage exceeds around 42V. This ensures that all the cells remain at the same state of charge, which aids in pack longevity and performance.

SAFETY INSTRUCTIONS



- When connecting your lithium battery for charging or discharging, always tighten connector bolts to the specified torque setting (pg. 5) with a torque wrench set, not by hand.
- If the connection is not secure and stable, the terminals could become very hot and cause internal damage to battery.
- Do not charge battery with an unregulated alternator or other unapproved chargers!
- Do not cross-circuit battery.
- Do not immerse battery in water.
- This battery is water resistant. Do not use in direct rain, spray or other wet conditions.

SAFETY INSTRUCTIONS



- Never charge or discharge battery with more than its rated amps.
- Built-in low temp charging protection. Do not charge if under 32°.
- Failure to follow the above instructions could be dangerous and can void the warranty.
- In case of deformation or leakage of the battery, immediately place outside and away from buildings, and contact a Millertech® representative right away. (see back cover for Millertech Energy Solutions, LLC contact information).

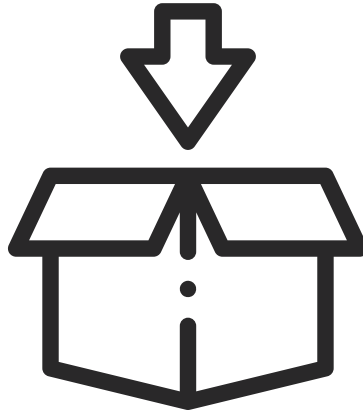

■ After removing your battery from the box and packaging, connect it to a charger and charge it completely. Batteries are not fully charged upon arrival due to shipping restrictions.

■ Connect with app (Bluetooth versions) and familiarize yourself with it's basic features and functions.

■ After the battery has been charged you are ready to install the battery in your application. If you have any questions about your install application, please feel free to contact us (see back cover for contact info).

INSTALLATION

The batteries may be connected in parallel, however, care must be taken in connecting to the battery terminals. The positive and negative terminals are marked on battery (see below).

WARNING! Do not reverse polarity the battery as this will damage both the battery and the device being connected!



All batteries ship with 18-8 stainless steel M8 bolts/washers. If multiple lugs are used the washers may be removed, or longer bolts may be required in order for the bolt to fully seat into the copper pillar.

Parallel & Current Specifications

(1) BATTERY	50A Maximum Charge - Discharge
(2) BATTERIES	75A Maximum Charge - Discharge
(3) BATTERIES	100A Maximum Charge - Discharge
(4) BATTERIES	150A Maximum Charge - Discharge

PARALLEL

Maximum of 4 units are supported for parallel connection. Please be sure all cables and connections, (fuses and/or breakers), are able to accommodate the maximum amperage the batteries are capable of providing. Appropriate fuses and breakers are highly recommended to protect components from current and voltage spikes. Voltages of all batteries being connected should be close before connecting.

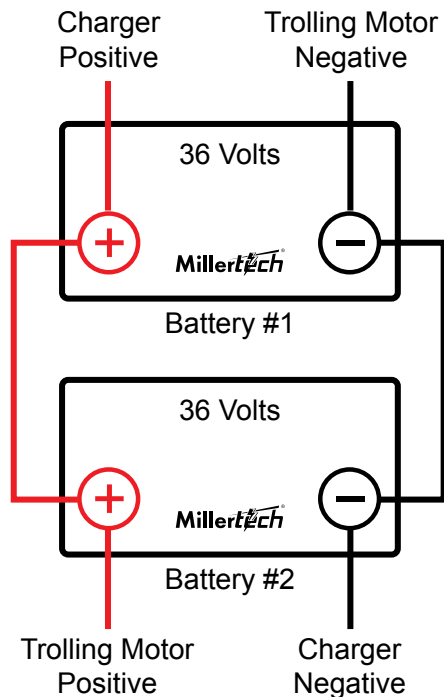

ABOUT THE APP

Download the Millertech® app on your device from wherever you normally download your apps.

Get as close as possible to the batteries you wish to connect with and open the app.

Allow permissions so your device can connect with your batteries via Bluetooth.

Compare the available device names to the labels on top of the batteries.

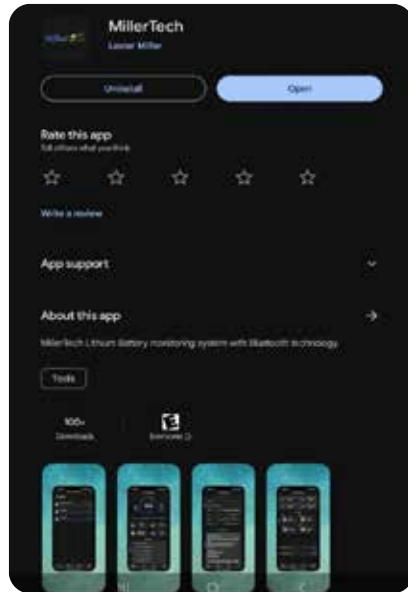

ABOUT THE APP

Tap the device name with which you wish to connect. After connection has been made swipe left on the device to access auto-connect feature.

On the bottom of the screen tap dashboard or control panel and you can now see all the info on the battery.

To connect to multiple batteries simply return to Bluetooth screen and tap devices you wish to add.





CYCLE LIFE

**80% REMAINING CAPACITY
AFTER THESE CYCLES**

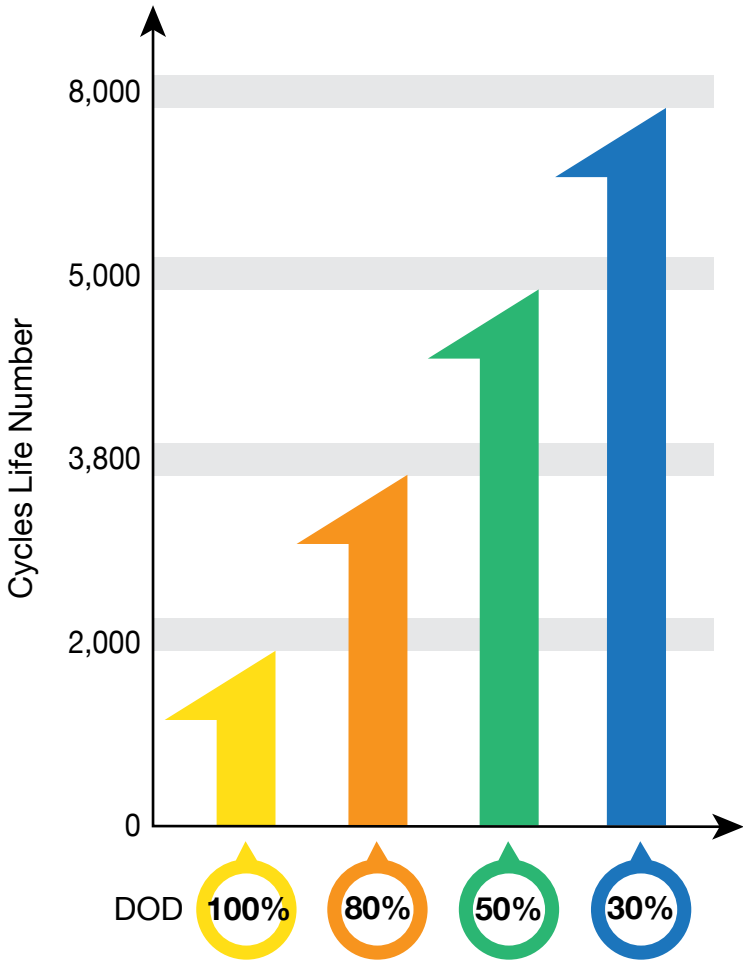

Cycle VS DOD Curve





I STORAGE

Storage could not be easier. Simply charge the batteries to at least 50% / 39.9V state of charge and disconnect from any charge or discharge and repeat this every quarter/3 months.



| WILL NOT CHARGE:

- Ensure charger works by connecting with another battery.
- Make sure battery is warm enough. Place in heated building at least 24 hours and retry charging.
- Check temp on dashboard/control panel.
- Check app for fault codes.

| WILL NOT DISCHARGE

- Ensure battery has enough charge left.
- Check loads to see if load is excessive.
- Check for short circuit.
- Check app for fault codes.



4 THINGS TO DO BEFORE YOU CALL TECH SUPPORT

- Have battery size/model.
- Calculate approximate purchase date.
- Be able to connect to the battery with phone app while on live call (Bluetooth models).
- Brand and model of charger being used.



WARRANTY



THE MILLERTECH® SPORT SERIES LITHIUM BATTERY 10 YEAR GUARANTEED WARRANTY *IS SIMPLE!*

✓ *TERMS:*

From the date of your battery purchase through year number 10 of ownership, your battery is covered. If it stops working during this time, we will repair or replace it with a battery of equal or greater value for FREE!

✓ *SHIPPING:*

We cover all shipping costs associated with shuttling your battery back and forth for repair or replacement. It is our warranty; it is our cost; not yours.

✓ *EXCLUSIONS:*

There are NONE! You trusted MillerTech®, and if it's within the warranty period your MillerTech® battery is completely covered for everything!

✓ *PROOF OF PURCHASE:*

You don't need one. If its MillerTech®, it's covered!

Contact Us Direct:

855-MAX-LITH (629-5484)

Warranty@millertechenergy.com



SPORT SERIES



MillerTech Energy Solutions LLC

14632 Old State Rd. Middlefield, OH 44062

Toll Free: 855-MAX-LITH (629-5484)

Fax: 440-548-2235

Email:

Sales@millertechenergy.com

Support@millertechenergy.com

Warranty@millertechenergy.com

Hours: Monday-Thursday 8-4 / Friday 8-3