



Dark Speed 12V-36V  
On-Board Lithium  
Battery Charger

Item# DS36

DARK SPEED CHARGER

# ***USER MANUAL***

# Thank You!

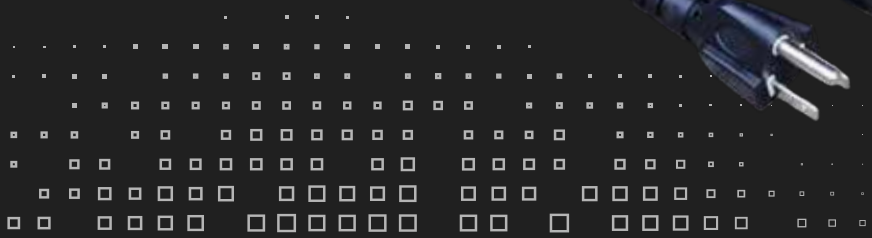

FOR YOUR BUSINESS,  
YOUR TRUST, AND CONFIDENCE  
IN MILLERTECH®.

*IT IS OUR  
PLEASURE  
TO SERVE  
YOU!*



**MillerTech**

# PRODUCT OVERVIEW



- 1 — Dark Speed 12V-36V On-Board Lithium Battery Charger
- 2 — Anderson Quick Connect 50A to M8 Ring Terminals

## **WATERPROOF & OVERHEAT RESISTANT**

Anodized aluminum housing is IP65 waterproof-rated, sturdy, durable and provides maximum surface space to dissipate heat and prevent overheating.

## **AUTOMATIC & BOAT MOUNTED**

Fully automatic lithium battery chargers are designed to be permanently mounted in your boat.

**Millertech**<sup>®</sup>

# CHARGING PARAMETERS

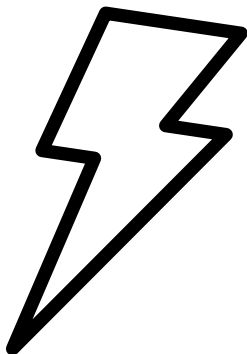

## *Specifications*

INPUT VOLTAGE	90-130V AC
AC POWER DRAW	857W
OUTPUT VOLTAGE 1	14.5V 15A
OUTPUT VOLTAGE 2	42.6V 15A
START TRANSFER VOLTAGE	14V
STOP TRANSFER VOLTAGE	13.3V
WATERPROOF	IP65
DIMENSIONS	10¾" x 7¾" x 3½"
WEIGHT	13.8 lbs.



## **I ON THE RUN CHARGING**

Connect the 12V lead to your starting battery and the 36V lead to your trolling motor battery. When your outboard motor's alternator has charged the starting battery to a preset voltage, the charger will automatically transfer power from your starting battery to your trolling motor battery at a safe rate. When the starting battery gets drawn down to a preset voltage, it stops transferring power until it is charged to the “start transfer” voltage again. It will continue this cycle as long as the starting battery keeps being charged by the alternator. This process will ensure you get maximum runtime from your trolling motor battery without worrying about draining your starting battery and ending up “dead on the water.”

# INSTALLATION

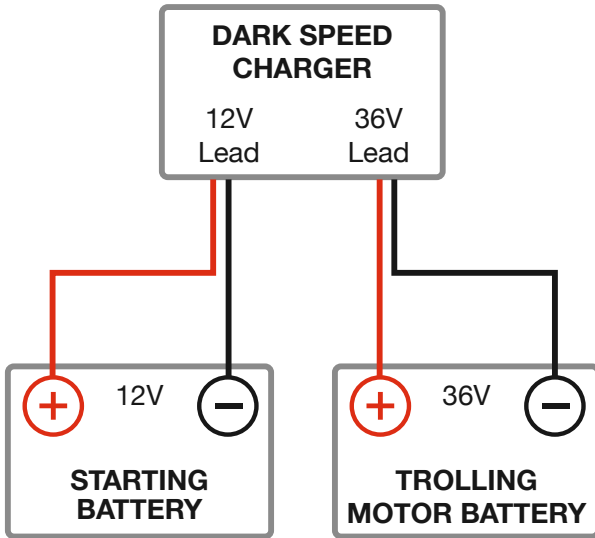



## AC CHARGING AT HOME

Plug the AC cord into your outlet and the charger will charge and maintain both your 12V and 36V battery.

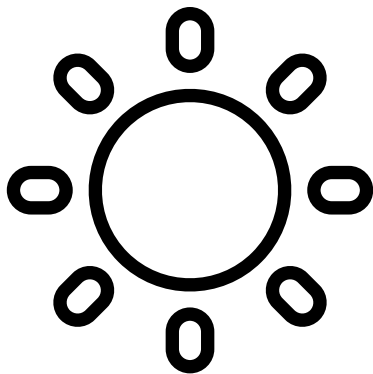
# LED INDICATOR



LED DISPLAY	STATUS
 SOLID	Not charging/Battery full.
 SOLID	Transferring power from starting battery to trolling motor battery.
 SOLID	Charging.



## **I WILL NOT CHARGE:**

- Ensure AC power is sufficient for the charger.
- Unplug charger from AC source, wait until all lights on the charger go out and plug in again.
- Ensure battery is not already fully charged.
- Check battery app for faults/error messages.

# WARRANTY



## THE MILLERTECH® MARINE CHARGER 3 YEAR GUARANTEED WARRANTY *IS SIMPLE!*

### ✓ *TERMS:*

From the date of your charger purchase through year number 3 of ownership, your charger is covered. If it stops working during this time, we will repair or replace it with a charger of equal or greater value for FREE!

### ✓ *SHIPPING:*

We cover all shipping costs associated with shuttling your charger back and forth for repair or replacement. It is our warranty; it is our cost; not yours.

### ✓ *EXCLUSIONS:*

There are NONE! You trusted Millertech®, and if it's within the warranty period your Millertech® charger is completely covered for everything!

### ✓ *PROOF OF PURCHASE:*

You don't need one. If its Millertech®, it's covered!

**Millertech®**

At Millertech, we constantly strive to  
provide the best marine battery system  
available in today's market.

Our technical innovation, for your simplicity.

**Contact Us Direct:**

855-MAX-LITH (629-5484)

Warranty@millertechenergy.com



## MillerTech Energy Solutions LLC

14632 Old State Rd. Middlefield, OH 44062

**Toll Free: 855-MAX-LITH (629-5484)**

Fax: 440-548-2235

Email:

[Sales@millertechenergy.com](mailto:Sales@millertechenergy.com)

[Support@millertechenergy.com](mailto:Support@millertechenergy.com)

[Warranty@millertechenergy.com](mailto:Warranty@millertechenergy.com)

**Hours:** Monday-Thursday 8-4 / Friday 8-3